

Place for customer logo
convexity/concavity marking 0.5mm

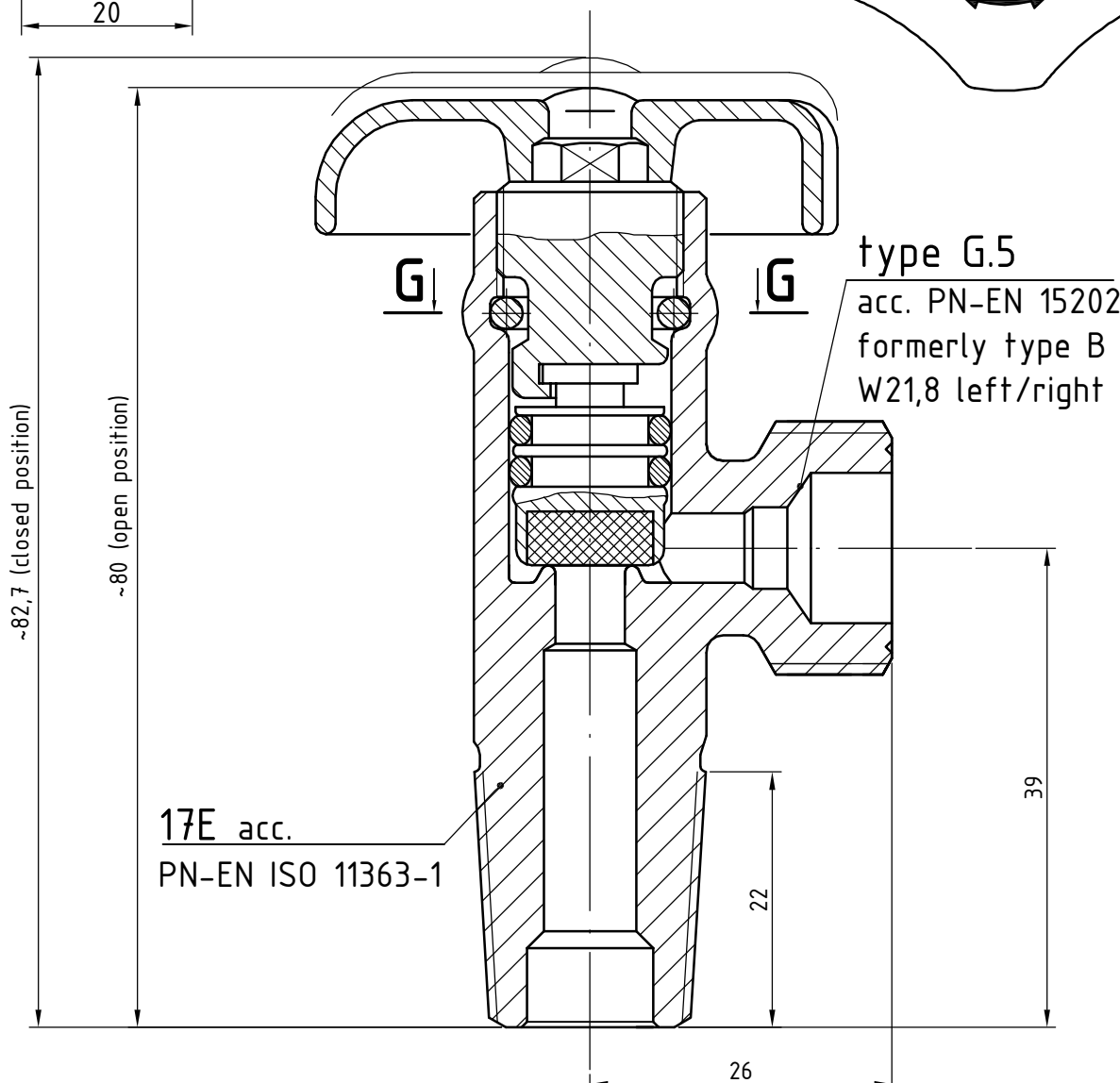

type G.5
acc. PN-EN 15202
formerly type B
W21,8 left/right

The manufacturer reserves the right to make design changes which not affect valve functionality and in conformity with the international standards.
Working temperature: -20 ÷ +60°C
Test pressure: 3MPa

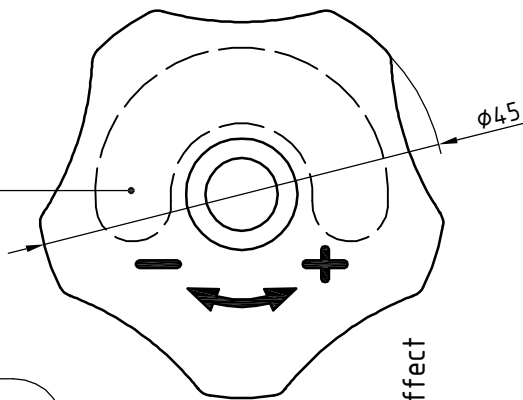
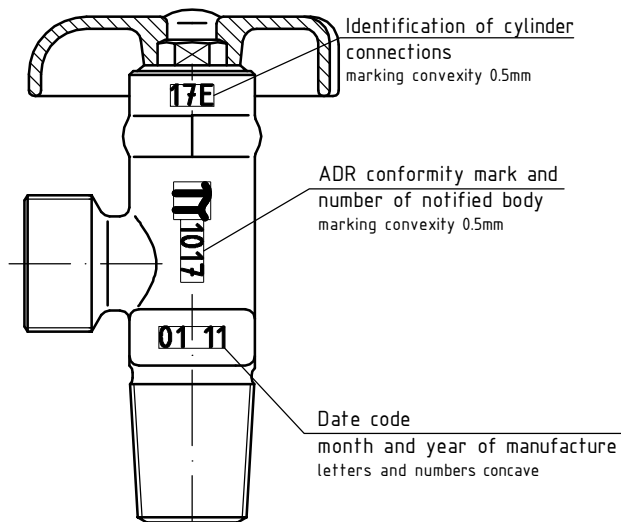

Identification of cylinder connections
marking convexity 0.5mm

ADR conformity mark and number of notified body
marking convexity 0.5mm

Date code
month and year of manufacture
letters and numbers concave

Manufacturer's logo - FAS
marking convexity 0.5mm

Number of European Standard
marking convexity 0.5mm

Quality Control Mark
letters and numbers concave

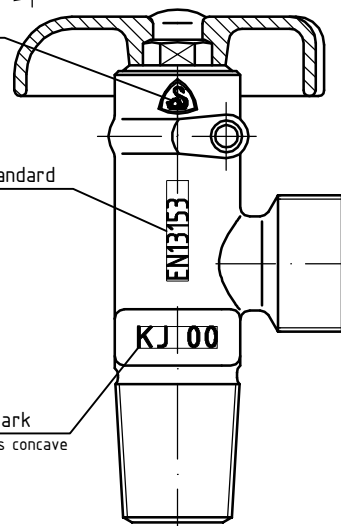

FABRYKA ARMATUR
"SWARZĘDZ"
sp. z o.o.

Gas cylinder valve (LPG)

type	Z6M/B	date	2012-01-23
draw.nr	Z6M/B-00.00/OF		